

2.5 & 5.0 GALLON PRESSURE TANKS

310597F

Includes:

MODEL 7025 2.5 Gallon Single Regulation (NON A.S.M.E.)**MODEL 7026** 2.5 Gallon Dual Regulation (NON A.S.M.E.)**MODEL 7027** 5.0 Gallon Single Regulation (NON A.S.M.E.)**MODEL 7028** 5.0 Gallon Dual Regulation (NON A.S.M.E.)

System Description

Pressure tanks provide pressurized material up to a maximum of 50 psi. This tank is equipped with a tank pressure regulator, air regulator (Model 7026 & Model 7028 only), gauge, safety valve, and fluid outlet. It is constructed of the finest materials available for durability. The increased capacity enables you to handle most any job with professional results. This versatile tank can also spray materials other than paint.

CAUTION

READ INSTRUCTIONS CAREFULLY BEFORE USING!

This pressure tank is not designed for highly abrasive, corrosive, or rust inducing materials. If used with such materials, frequent and thorough cleaning is advised to reduce the necessity for replacement of parts.

WARNING

AIR PRESSURE LOADS THAT ARE HIGHER THAN DESIGN LOADS, OR ALTERATIONS TO THE PRESSURE FEED TANK CAN RESULT IN TANK RUPTURE OR EXPLOSION.

A SAFETY VALVE PROTECTS THE TANK FROM OVER PRESSURIZATION. DURING EACH USE, PULL THE RING ON THE SAFETY VALVE TO CHECK IF IT OPERATES FREELY AND RELIEVES AIR PRESSURE. IF THE VALVE IS STUCK, DOES NOT OPERATE FREELY, OR DOES NOT RELIEVE AIR PRESSURE, IT MUST BE REPLACED. DO NOT DISCARD OR MAKE ANY ALTERATIONS OR SUBSTITUTIONS TO THIS VALVE.

DO NOT MAKE ANY CHANGES TO THE PRESSURE TANK. TAMPERING IN THE FORM OF DRILLING, WELDING, ETC. WILL WEAKEN THE TANK.

THE MAXIMUM OPERATION PRESSURE OF THE TANK IS 50 PSI (0.34 MPa, 3.4 bar).



**Model 7025 - 2.5 Gallon Pressure Tank
Model 7027 - 5.0 Gallon Pressure Tank
Single Regulation (Shown)**

2.5 & 5.0 GALLON PRESSURE TANKS

Installation

Follow the manufacturer's directions for the mixing and preparation of material. Strain material using a fine mesh screen in order to prevent the entry of foreign matter and the clogging of passageways.

1. Prior to use, always relieve all air pressure in the tank. Pull the ring on the safety valve until the pressure bleeds down.
2. Slowly loosen the thumb screws, tip the lid clamps back, and remove the lid assembly.
3. Pour material into the tank. Use Model 7050 Disposable Tank Liners (for 2.5 gal. only) for "Easy Clean-up".
4. Replace the lid assembly and tighten the clamps and thumb screws securely.
5. It is best for the air supply line to pass through a SHARPE Air Control Unit to filter dirt from the air and extract water and oil. Connect the air supply hose to the air inlet fitting on the tank regulator as shown below.
6. Attach the atomization air hose to the air outlet fitting which is directly opposite air inlet fitting on the tank pressure regulator.
7. Connect the material hose to the fluid outlet fitting on top of the tank lid.
8. Refer to the figure below for a typical assembly.

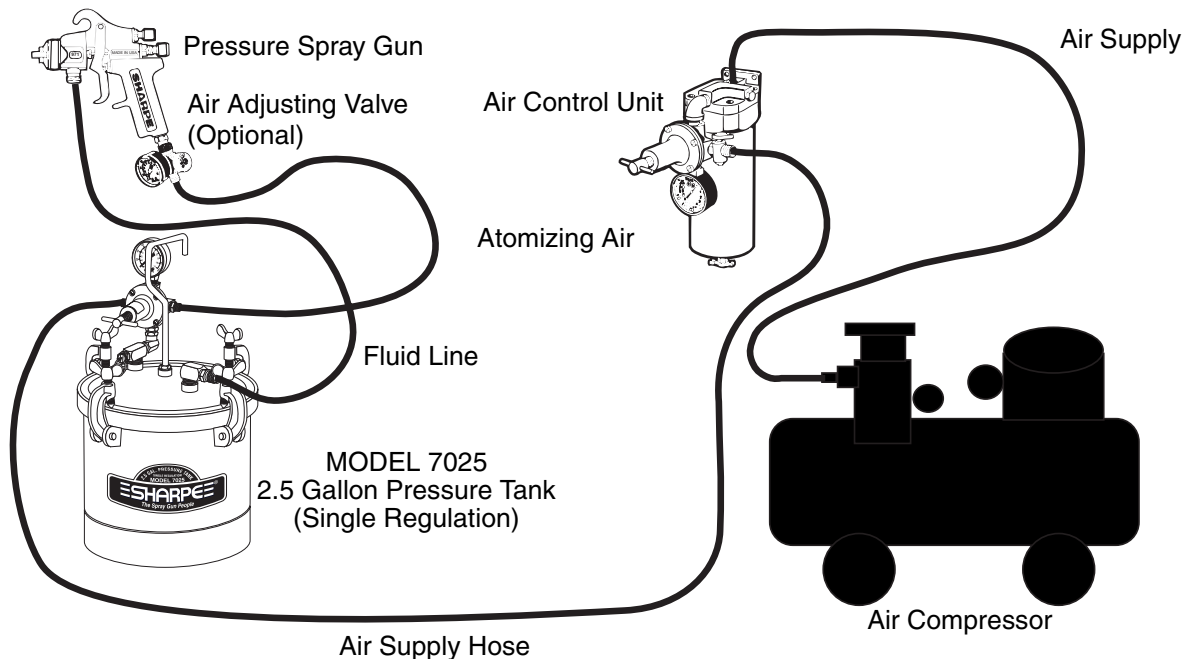

Operation

1. Turn on the air supply.
2. Turn T-handle adjusting screw clockwise on the tank pressure regulator while pulling the gun trigger fully back to commence material flow. Continue clockwise until desired material flow is achieved. To decrease pressure turn T-handle counter clockwise to a lower setting and then relieve pressure in tank by pulling the ring on the safety valve. **Maximum tank pressure is 50 psi.**
3. Atomization air for the spray gun can be adjusted at the gun by means of an air adjusting valve on the spray gun or at the air regulator assembly (Model 7026 and Model 7028 only) on the pressure tank.
4. Operate spray gun according to instructions accompanying gun.

2.5 & 5.0 GALLON PRESSURE TANKS

Maintenance: Cleaning your tank.

1. Turn off the main air supply to the tank.
2. Relieve all pressure from the tank by pulling the ring on the safety valve until the pressure bleeds down.
3. Turn the T-handle adjusting screw on the regulator counterclockwise until no spring tension is felt.
4. Slowly loosen thumb screws, tip clamps back, and tip tank lid to one side.
5. Loosen the spray gun air cap ring about three turns.
6. Turn on the air supply.
7. Hold a cloth over the air cap on the gun and pull trigger. This will force material back through the hose, and into the tank.
8. Empty and clean the tank and parts that come in contact with material. Use a suitable solvent.
9. Pour solvent into the tank.
10. Replace the lid and tighten thumb screws and clamps.
11. Turn the T-handle on the tank regulator clockwise while pulling the trigger fully back and spray until clean solvent appears.
12. Repeat steps 1 through 3.

IMPORTANT: KEEP THE SAFETY VALVE CLEAN AT ALL TIMES.

NOTE: Decorative powdercoating may be affected by solvent contact. Avoid prolonged exposure of powdercoated areas to solvents. The tank has been Zinc-plated underneath the decorative coating for rust protection.

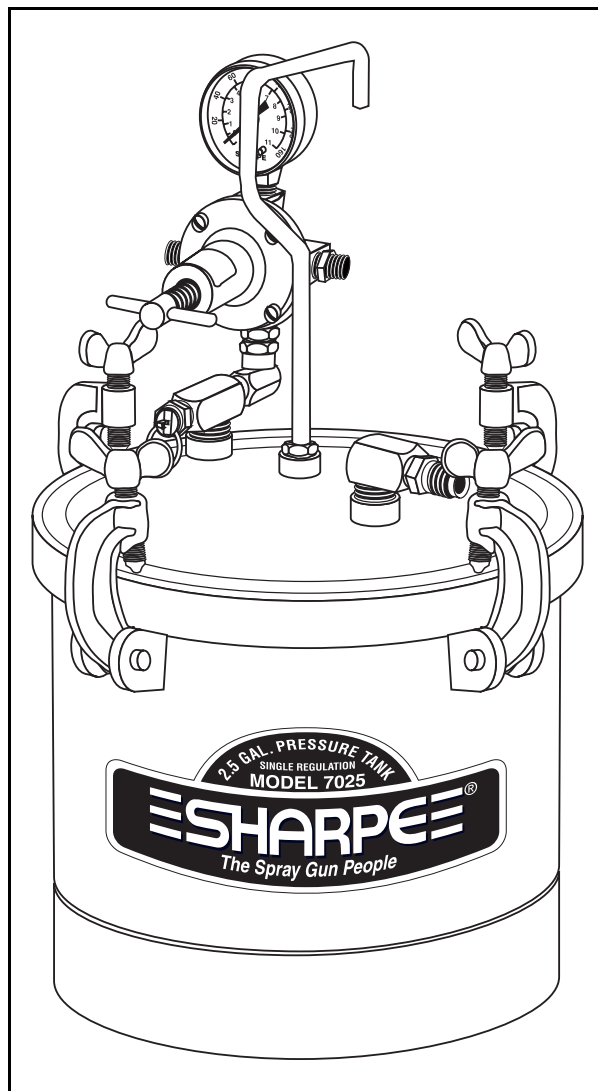

Troubleshooting

CONDITION	CAUSE	CORRECTION
Air escaping from the hole on the regulator bonnet.	Broken or damaged diaphragm.	Replace diaphragm.
Pressure creepage registering on the gauge.	Dirty or worn valve seat in regulator.	Clean or replace valve seat.
Fluid or air leaking at the lid gasket.	Defective lid gasket or thumb screws not tight.	Replace or tighten.

2.5 & 5.0 GALLON PRESSURE TANKS

FLUID PRESSURE REGULATOR (U10004) PARTS LIST

PART NO.	DESCRIPTION
8220	FLUID PRESSURE GAUGE
9993	NIPPLE - 1/4 in.
10001	REGULATOR BODY
10003	REGULATOR BONNET
U10005	VALVE SEAT
U10006	VALVE SPRING
U10008	VALVE BODY
10010	VALVE STEM
10013	WIRE SCREEN
10015	DIAPHRAGM ASSEMBLY
10016	PRESSURE SPRING
10018	SPRING WASHER
10019	VIBRATION DAMPER
10022	ADJUSTING SCREW
10023	SCREW

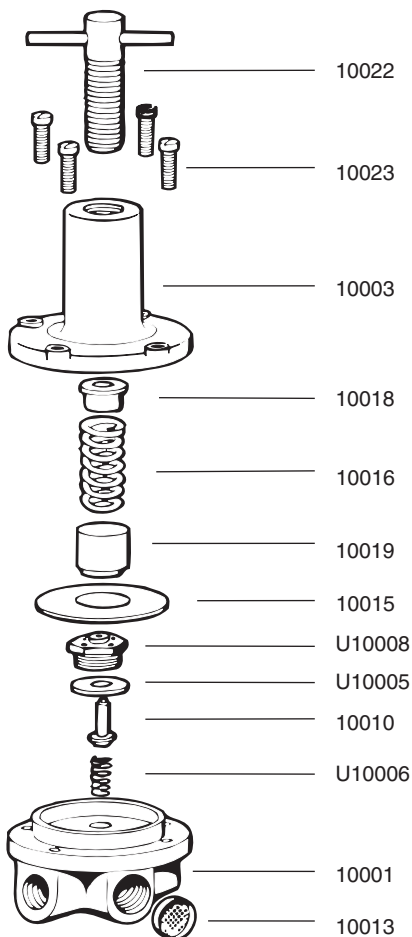

FLUID PRESSURE REGULATOR (U10004)

MODEL 7025 & 7027 PARTS LIST

PART NO.	DESCRIPTION
9993	NIPPLE
U10004	FLUID PRESSURE REGULATOR
23001	FLUID TUBE (7025 & 7026 ONLY)
23072	FLUID TUBE (7027 & 7028 ONLY)
U23002	LID ASSEMBLY
23007	LID GASKET, THIOKOL
23020	SAFETY VALVE
23040	SWIVEL ADAPTOR
U23042	BRANCH TEE
23050	TANK HANDLE
23051	HANDLE HEX NUT
U23062	STREET ELBOW
23065	YOKE ASSY. w/Thumb Screw
23070	HINGE PIN w/"E" Clip

ADDITIONAL REPLACEMENT PARTS - Model 7026 & 7028 (Dual Reg.)

1630	AIR PRESSURE REGULATOR
8230	AIR PRESSURE GAUGE
9993	NIPPLE - 1/4 in.
10028	PLUG
23045	CLOSED NIPPLE - 1/4 in. REDUCER
Accessories	
BF07050	TANK LINER, not shown (7025 and 7026 only) 2.5 gal only

MODEL 7025 (SINGLE REG.)

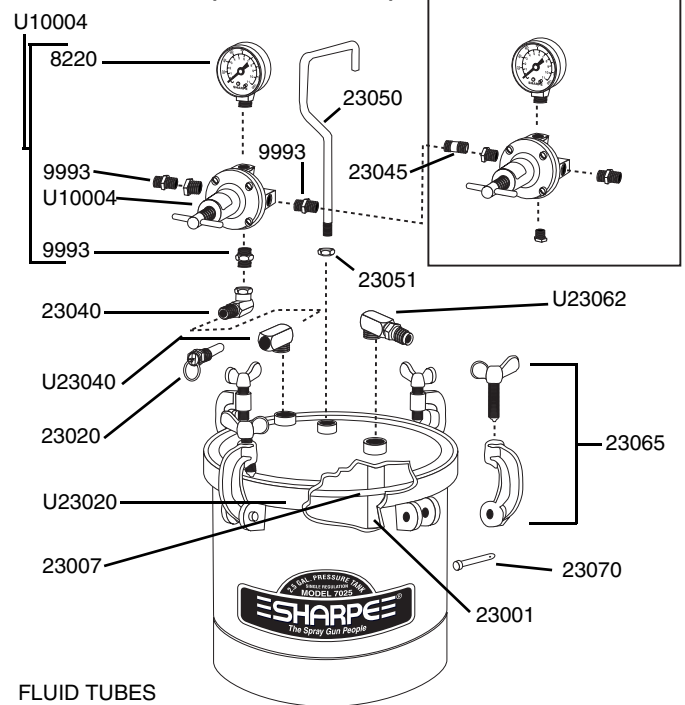

FLUID TUBES
23001 (For Models 7025 & 7026
23072 (For Models 7027 & 7028

**MODEL 7025 & 7027
2.5 & 5.0 GALLON PRESSURE TANK
(NON A.S.M.E.) SINGLE & DUAL REGULATION**

2.5 & 5.0 GALLON PRESSURE TANKS

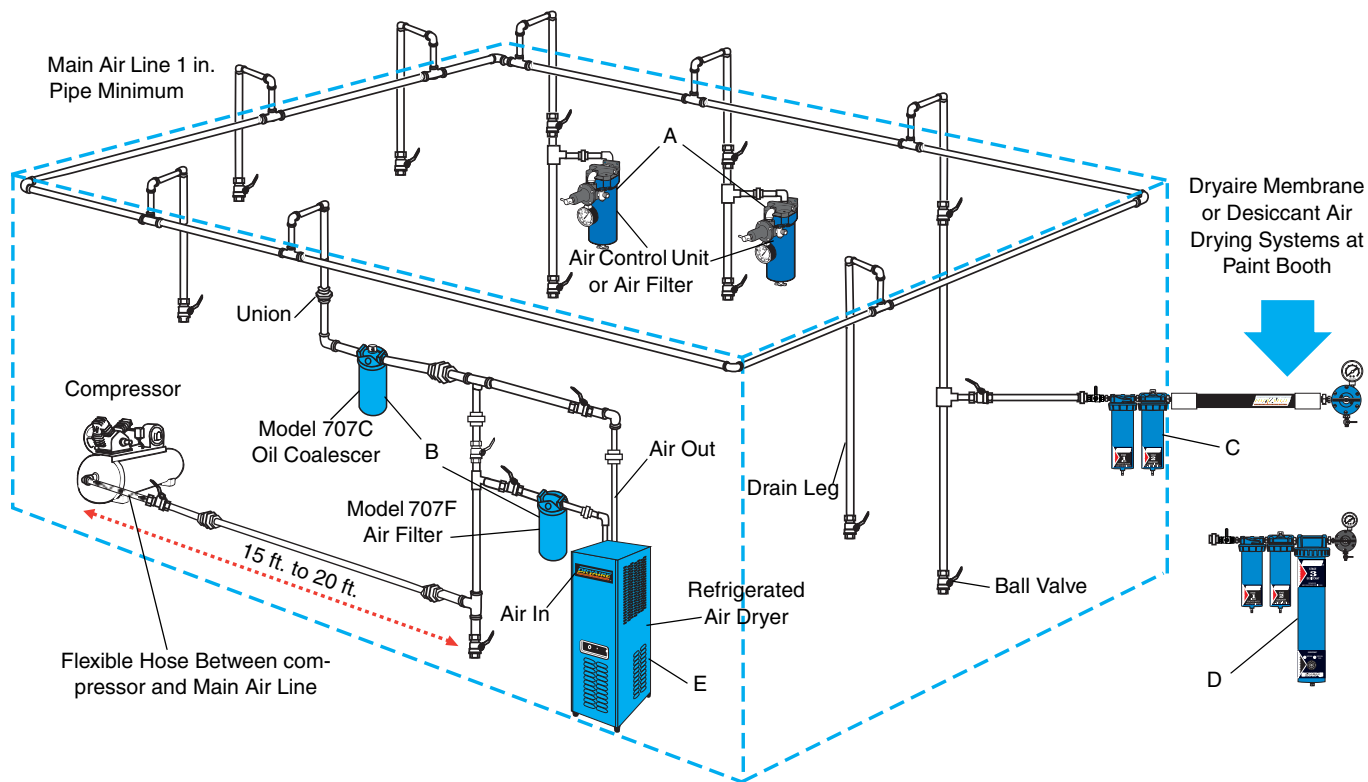

Ref. Letter	Description	Model No.
A	Sharpe 606	U06710
	Sharpe 606A	U06720
	Sharpe 606B	6730
	Sharpe 880A	6950
	Sharpe F88	8130
B	707C	6930
	707F	6920
	707FC	6910
C	Dryaire Membrane	6770
D	Dryaire Desiccant	6760
E	Refrigerated Air Dryer	
	25CFM	6880
	35CFM	6885
	50CFM	6890
	75CFM	6895