

Sharpe, a leader in paint spraying equipment for the professional automotive refinish market, introduces the newly-designed, high performance RAZOR Waterborne Spray Guns.

**RAZOR**<sup>®</sup>  
WATERBORNE



**RAZOR**<sup>®</sup>  
WATERBORNE



**Razor Waterborne Gun System**

When considering a complete gun system, the Razor product line has a primer, base and clear solution for all your automotive paint spraying needs.



HVLP Primer      HVLP Waterborne Base Coat      LVL Clear Coat

SHARPE MANUFACTURING COMPANY  
MINNEAPOLIS, MN USA 55413  
PHONE 800-SHARPE1

[www.sharpe1.com](http://www.sharpe1.com)



- Superior atomization
- Lightweight and ergonomic
- 3 year warranty
- Made in USA

**RAZOR Waterborne Spray Guns** are optimized for waterborne base coats. The 100% stainless steel fluid passages are impenetrable to corrosion. The 23 ounce plastic cup is easy to clean and necessary since waterborne paint can corrode metal cups.

In response to feedback from painters in the automotive refinish market, RAZOR Spray Guns are designed to be lightweight, ergonomic and deliver a high quality automotive finish.

**SHARPEE**<sup>®</sup>  
A GRACO COMPANY

**SHARPEE**<sup>®</sup>  
A GRACO COMPANY

©2007-2008 Graco Inc.  
Form Number 339733 Rev. B

## Premium Performance & Quality

RAZOR Waterborne spray guns have a nickel-plated finish, 100% stainless steel fluid passages, stainless steel needle and nozzle, 3M™ PPS™ Adapter and a 23-ounce plastic cup.

Spray Type	Size (mm)	Gun PN	Applications
HVLP Waterborne	1.2	289388	Waterborne base coats
HVLP Waterborne	1.3	289389	Waterborne base coats
HVLP Waterborne	1.4	289571	Waterborne base coats
Compliant Waterborne	1.2	289390	Waterborne base coats
Compliant Waterborne	1.3	289391	Waterborne base coats
Compliant Waterborne	1.4	289572	Waterborne base coats

## Zephyr™ Gun

This easy to use gun is designed to decrease the drying time of waterborne paint using compressed air. Can be used freehand or attach to the Zephyr Gun Stand. Intake filter will prevent contamination of vehicle surface.



Zephyr Gun PN: 289956

Working Pressure . . . . . 10-60 psi (0.7-4 bar, 0.07-0.4 MPa)  
 Maximum Pressure . . . . . 175 psi (12 bar, 1.2 MPa)  
 Air Consumption @ 60 psi (4 bar, 0.4 MPa) . . . . . 17.5 scfm  
 Weight . . . . . 485 g (17.1 oz)

### HVLP Waterborne

When HVLP is required, the Razor Waterborne guns will provide a well-defined spray pattern for superior material distribution.

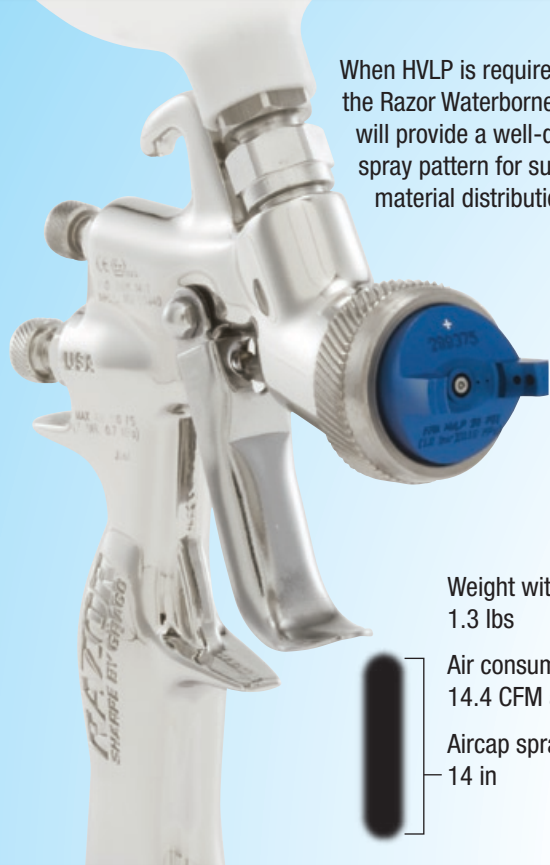

Weight with cup:  
1.3 lbs

Air consumption:  
14.4 CFM at 29 psi

Aircap spray pattern:  
14 in

### Compliant Waterborne

Compliant technology is capable of atomizing higher viscosity materials and offer higher production rates when compared to HVLP.



Weight with cup:  
1.3 lbs

Air consumption:  
11.2 CFM at 35 psi

Aircap spray pattern:  
14 in

## 360° Zephyr™ Gun Stand

The 360° Zephyr Gun Stand can hold up to 2 guns. The stand is portable and offers variable positioning with quick disconnect couplers.

Zephyr Gun Stand  
PN: 289957

Contains:  
2 piece quick coupler,  
2 piece PU hose,  
3 piece airway

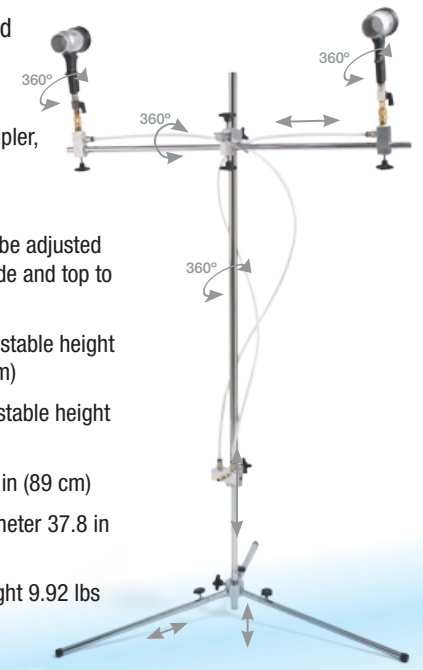

- Foot shelf can be adjusted from side to side and top to bottom
- Maximum adjustable height 82.7 in (210 cm)
- Minimum adjustable height 7.9 in (20 cm)
- Pole length 35 in (89 cm)
- Foot Shelf diameter 37.8 in (96 cm)
- Foot Shelf weight 9.92 lbs (4.5 kg)

Zephyr Guns & Gun Stand Kit  
PN 289958

## Additional Product Information

